

Media Information

2012

pet

Fachmagazin für die Heimtierbranche



www.PETonline.de



Dähne Verlag

Dähne Verlag GmbH
P.O. Box 10 02 50
76256 Ettlingen (Germany)
Phone +49 / 72 43 / 575-104
Fax +49 / 72 43 / 575-100
advertising@daehne.com
www.daehne.com

Media Information

Editorial and publishing analysis

pet

In brief

pet is the specialist magazine for the German-speaking pet sector. Contributions from Austria and Switzerland are included to complement the reports on the German market. Every issue brings up-to-date and practical information on all the different aspects of the pet market. The magazine focuses on news and personnel announcements from the sector, trade fair reports, coverage of the specialty pet trade and the pet departments in garden centres and DIY stores, as well as reports on suppliers and service concepts. Regular market and product surveys, in addition to detailed keynote topics, deal with developments in a variety of different product areas. Expertly analysed statistics provide readers with information on the current state of the pet market.

Membership

IVW, VDZ, SZV

Publisher

Karl-Heinz Dähne

Chief editor

Ralf Majer-Abele

Editorial team

Philipp Gardemin,
Hans-Ludwig Ziegler

Advertising

Thomas Heinen, Patricia Bader

Volume

Volume 33, 2012

Frequency of publication

11 x (see enclosed schedule)

Publishing house

Dähne Verlag GmbH

Postal address

P.O. Box 10 02 50, 76256 Ettlingen,
Germany

Delivery address

Am Erlengraben 8, 76275 Ettlingen,
Germany

Telephone + 49 (0) 72 43 / 575-103

Fax + 49 (0) 72 43 / 575-100

E-mail advertising@daehne.com

Internet www.PETonline.de

Subscription rates

Annual subscription all countries

€ 103.– incl. p + p

Terms of payment

Net payment due within 20 days
of date of invoice

Terms + Conditions

www.daehne.de/media

Accounts

- (D) Deutsche Bank; Kaiserstr. 90
D-76133 Karlsruhe, Nr. 714 600 00
(BLZ 660 700 04)
BIC: DEUTDE33
IBAN: DE68 6607 0004 0071 4600 00
- (A) Raiffeisenverband Salzburg
Nr. 160 178 65 (BLZ 35000)
BIC: RVSAAT2S
IBAN: AT84 3500 0000 1601 7865
- (CH) Coop Bank Basel
Nr. 481116.290000-8
Clear. Nr. 8440, PC-Kto 40-8888-1
BIC: COOPCH33
IBAN: CH84 0844 0481 1162 9000 0

Media Information

Circulation | Target groups | Editorial content

Circulation auditing



Circulation analysis:

Copies per issue represent an average for
(2. Quartal 2011)

Print figure	6 281
Actual circulation	5 934
Remainder and file copies	347
Paid circulation	1 955
Subscriber copies	1 851
Single copies	104
Free copies	3 979

Geographical analysis of circulation

Actual circulation	100.0 %	5 934
Germany	95.3 %	5 654
Other	4.7 %	280

Analysis

2010 = 11 issues

Total size

779 pp = 100.0 %

Editorial

530 pp = 68.1 %

Advertising

249 pp = 31.9 %

of which

Bound-in inserts 0 units = 0.0 % } of

Loose inserts 6 units = 2.4 % } advertising

Analysis of 2010 editorial component

Total	530 pp = 100.0 %
Trade	84 pp = 15.8 %
Industry	67 pp = 12.6 %
News	80 pp = 15.0 %
Trade fairs/events	85 pp = 16.0 %
New products	29 pp = 5.4 %
Main focus/special	114 pp = 21.4 %
Others	73 pp = 13.7 %

Circulation by target groups

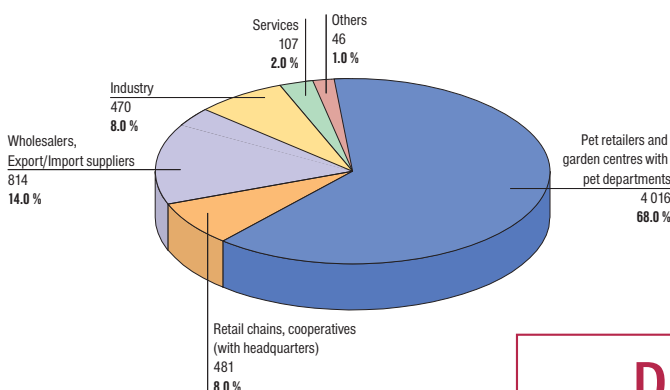

Dähne Verlag



Advertisement formats and rates

Format

210 mm width, 297 mm depth, DIN A 4

Type area

187 mm width, 270 mm depth

Columns

4 columns, 43 mm wide

Printing and binding processes

Offset printing and stapled binding

Copy

Copy up to 70 lines per cm/300dpi.
However, please pay careful attention to the technical instructions.

Frequency of publication

Monthly, July/August bimonthly

Publication dates

Refer to schedule

Advertising deadlines

Refer to schedule

Format	Number of columns	Width x Depth in mm	Basic price black/white €	2 colours €	3 colours €	4 colours €
1 / 1 page	4- columns	187 x 270	1 933.-	2 588.-	3 243.-	3 898.-
1 / 2 page	4- columns 2 columns	187 x 133 horizontal 91 x 270 vertical	980.-	1 380.-	1 780.-	2 180.-
1 / 3 page	4 columns	187 x 87	660.-	930.-	1 200.-	1 470.-
1 / 4 page	4 columns 2 columns 1 columns	187 x 64 horizontal 91 x 133 vertical 43 x 270	510.-	700.-	890.-	1 080.-
1 / 8 page	4 columns 2 columns 1 columns	187 x 30 horizontal 91 x 64 vertical 43 x 133	260.-	400.-	540.-	680.-
1 / 16 page	2 columns 1 columns	91 x 30 horizontal 43 x 64 vertical	150.-	250.-	350.-	450.-
back cover	4 columns	187 x 270	2 750.-	3 405.-	4 060.-	4 715.-
inside front cover	4 columns	187 x 270	2 420.-	3 075.-	3 730.-	4 385.-
inside back cover	4 columns	187 x 270	2 140.-	2 795.-	3 450.-	4 105.-

Rate per single-column millimetre: € 2.40 in advertising section, € 4.23 in editorial section

Surcharges and other prices

Surcharges per standard colour (Euro scale)/special colour (basic 4c)

≥ 1/1 page	€ 655.-	1/4 page	€ 190.-
1/2 page	€ 400.-	1/8 page	€ 140.-
1/3 page	€ 270.-	≤ 1/16 page	€ 100.-

HKS, pantone and metallic colour extra surcharge € 250.-

Special formats/positions

2/1 page	on request
Front cover flap	see extra information
Guaranteed positions	€ 240.-
Print over gutter margin	€ 185.-
Bleed additional 3 mm	10 % of basic rates

Small advertisement rates

Situations vacant per mm	€ 2.40
Private situations wanted per mm	€ 1.80
Charge for box number	€ 6.00

All employment ads will also appear for one month free of charge on www.PETonline.de

Rubric PET@Internet

Standard entry (company, internet address)	€ 20.-
Maxi entry (logo, company, internet address)	€ 70.-
Premium entry (logo, company, internet address, random rotating banner at www.PETonline.de)	€ 115.-
Minimum period of 6 issues	

Products + Services – price per millimetre

Only advertisements placed for a minimum period of 6 months can be included under this heading. Orders will be invoiced following the first insertion and by the end of each half-year.

black/white	€ 2.25
2 colours	€ 2.38
3 colours	€ 2.51
4 colours	€ 2.65

Discounts

Valid for one year	3 x 3 %
from publication date	6 x 5 %
of first insertion	11 x 10 %

Frequency rates

Volume rates

1 page	3 %
3 pages	5 %
6 pages	10 %
11 pages	15 %

Bound inserts

4-sided	€ 4 060.-	6-sided	€ 6 090.-	8-sided	€ 7 720.-
---------	-----------	---------	-----------	---------	-----------

Loose inserts

Maximum size 205 x 292 mm	
Up to 25 g %	€ 254.-
Up to 50 g %	€ 300.-

Adhesive postcard

% € 176.-

Delivery address for inserts

Kraft Druck GmbH
Betr.: pet No. ...
Industriestraße 5
76275 Ettlingen (Oberweier), Germany

A sample copy must be supplied in advance to Dähne Verlag GmbH, Advertising dept, P.O. Box 10 02 50, 76256 Ettlingen, Germany

Media Information

Schedule and editorial topics



Issue	Schedule	Keynote topics
1 January	Publication date 12.01.2012 Advertising deadline 12.12.2011 Copy deadline 15.12.2011 Editorial deadline 05.12.2011	Care products for dogs: Cleansing agents, brushes, combs, clippers, grooming accessories
2 February	Publication date 07.02.2012 Advertising deadline 13.01.2012 Copy deadline 16.01.2012 Editorial deadline 04.01.2012	Shop fitting: Sales displays, aquarium and terrarium construction, POS activities and secondary placement Sales promotions 2012: Manufacturers present ideas
3 March	Publication date 06.03.2012 Advertising deadline 07.02.2012 Copy deadline 09.02.2012 Editorial deadline 01.02.2012	Garden pond ranges: Cold water fish, aquatic plants, care products, pond food, pond liners, fountains, lighting, pumps, filter systems and other accessory products
PET Buyers' Guide 2012	Publication date 15.03.2012 Advertising deadline 25.01.2012 Copy deadline 26.01.2012	The PET Buyers' Guide is an indispensable aid for the pet product trade. Categorised according to range, it offers a handy overview of the leading suppliers and wholesalers in the pet sector. The Buyers' Guide also includes contact data for the most important service companies operating in the pet product sector as well as an overview of the top firms in the garden sector. Please ask for our special media rates.
4 April	Publication date 03.04.2012 Advertising deadline 06.03.2012 Copy deadline 08.03.2012 Editorial deadline 28.02.2012	Over-the-counter medicines, care products and food supplements for pets: Tick and flea collars, dental care products, conditioning products
5 May	Publication date 02.05.2012 Advertising deadline 04.04.2012 Copy deadline 11.04.2012 Editorial deadline 14.03.2012	Main fair issue: Interzoo, Nuernberg, Germany, 17 – 20 May Packaging + recycling: Innovative solutions for the pet supplies sector
6 June	Publication date 13.06.2012 Advertising deadline 16.05.2012 Copy deadline 23.05.2012 Editorial deadline 09.05.2012	After fair report: Interzoo 2012 Dog food: Premium food, chews, treats, special food and single-serve products
7-8 July-August	Publication date 10.07.2012 Advertising deadline 12.06.2012 Copy deadline 14.06.2012 Editorial deadline 05.06.2012	Outdoor products for pets: Leads, collars, clothing, outdoor toys, sports and agility, GPS systems
9 September	Publication date 23.08.2012 Advertising deadline 26.07.2012 Copy deadline 02.08.2012 Editorial deadline 19.07.2012	Freshwater aquariums: Fish wholesalers, fish food, filters and pumps, aquariums, aquarium lighting, nano-aquariums, invertebrates Doves, chickens, ducks & co: Assortments for small and hobby livestock
10 October	Publication date 27.09.2012 Advertising deadline 06.09.2012 Copy deadline 07.09.2012 Editorial deadline 23.08.2012	Main fair report: Zooevent/Gartenevent, Kassel, Germany, 13 – 14 October Cat food: Premium food, treats, pouches, tinned and tray products, special food
11 November	Publication date 08.11.2012 Advertising deadline 11.10.2012 Copy deadline 19.10.2012 Editorial deadline 04.10.2011	Main fair issue: Zooevent/Gartenevent 2012
12 December	Publication date 06.12.2012 Advertising deadline 08.11.2012 Copy deadline 15.11.2012 Editorial deadline 01.11.2012	Bioproducts: Pet food, care and treatment products, miscellaneous pet spezial: New products of the year
1/ 2013	Publication date 08.01.2013 Advertising deadline 05.12.2012 Copy deadline 07.12.2012 Editorial deadline 28.11.2012	

Media Information

Special forms of advertising: Pocket



The **pet** pocket is a special insert in a handy DIN A6 format (147 mm high and 104 mm wide), which is glued into an issue of **pet**. The editorial team produces the contents in collaboration with the client.

The layout is the “**pet** Layout”, which gives the product a high degree of credibility. Depending on the issue, this presentation option is offered exclusively to just one company.

pet Pocket standard (20 pages in total)

1 title page, 18 pages of content, 1 full-page advert 4c € 7 497.-

pet Pocket XL (28 pages in total)

1 title page, 25 pages of content, 2 full-page adverts 4c € 9 639.-

pet Pocket XXL (36 pages in total)

1 title page, 32 pages of content, 3 full-page adverts 4c € 11 781.-

The pocket is glued onto an editorial “carrier page”, which also features content on the client’s company.

Additional services: Publication on www.PETonline.de, 100 specimen copies, higher circulation for an additional charge.



Media Information

Prize draw sponsoring

The sponsorship model for the “**pet** prize draw” is the ideal way to complement your product advertising, especially when launching a product or to support seasonal promotions.

Sponsoring Standard

1/1 page prize draw with product and company presentation 1 600.-

Sponsoring Premium

1/1 page prize draw with product and company presentation + announcement with logo on grip corner of title page (approx. 5 cm x 5 cm x 7 cm) € 2 100.-

Basic terms:

The sponsor provides prizes to the value of at least € 250.00.

pet trade magazine features 1/1 page 4c on which the promotion is presented with:

- Name listing as cooperative partner with logo (Win with pet and “sponsor”)
- Product image, approx. ¼ page (jpg, pdf with 300 dpi)
- Company/product information, approx. ¼ page

(Heading max. 50 characters; 1100 characters of text for the presentation; 190 characters prize draw description, incl. of spaces respectively)

The prize draw in each issue is staged with just one exclusive sponsor.



Media Information

Special advertising formats

Got an idea for an unusual advertising format?

Want your ad to be even more striking?

Then talk to us. We work with you to realise advertising formats that attract greater attention. No matter whether they're island advertisements, L-adverts, round adverts, adverts with punched-out parts, fold-out pages, magazine banderoles – there's a host of possibilities!

We'll turn your ideas into reality, to make your advertising even more noticeable.

spago
Die Gartenzeitschrift
1911-1912-2012

Zahl des Monats

Umsatzzugang im ersten Halbjahr

Maxi Bahn und Europa

Die schönsten Ecken im Garten

Example:
L-advert
across spine



All prices exclusive of VAT.



Dähne Verlag

Media Information

Cover flap advertisements

pet

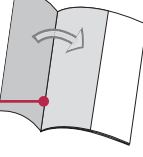
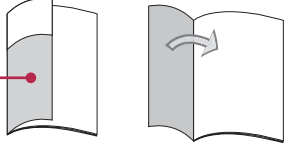
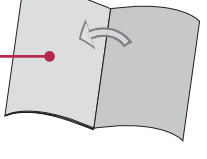
Cover flap advertisements are placed on additional fold-out pages on the cover:

Cover 1 ½ page inside left cover flap (1/2 cover)	€ 3 463.-		Cover 1
Cover 2 1/1 page (over gutter margin) inside left cover flap (1/2 cover) and left half side cover	€ 5 195.-		Cover 2
Cover Special 2 columns/187 mm high below the magazine logo outside the left cover flap (1/2 cover) + ½ page on the same cover flap inside	€ 5 626.-		Cover Special
Cover XXL The complete cover flaps to the right Inside is a 2/1 page ad over gutter margin	€ 9 630.-		Cover XXL
Cover Gate 2 cover flaps (1/2 cover to the left and ½ cover to the right) with an 2/1 page ad over both gutter margins	€ 9 318.-		Cover Gate

Media Information

Procedures and specifications for the supply of advertising material

All data must be supplied as print quality PDF or directly processable EPS.

Please also ensure that

- all colours are created as CMYK or desired special colours;
- all directly processable images and graphics are encapsulated;
- all type fonts used are encapsulated;
- images are stored exclusively in bitmap, grey-scale or CMYK mode.
By no means may "indexed" colours, RGB or other modes be used.
Image format either TIFF or EPS.
- images are not stored as DCS images, since we process uncompartmented data. We must be informed if any DCS images are included in the material (to avoid any possibility of accidentally poor resolution). If you do include any DCS images, we will convert them and invoice you as appropriate.
- you provide a reliable colour printout of the data, since we have no other way of checking the accuracy of the proof.

We can not guarantee correct reproduction unless we receive your colour printout before the copy closing date. This is particularly important for colour reproduction.

Data transfer by E-mail

Such files should not exceed 20 MB in size. E-mail: copy@daehne.com

Data file upload via FTP

Send us an E-mail to copy@daehne.com and ask for your personal log-in information.

Please utilise the following procedure for naming your file

Abbreviation* of publication title + issue number + name of advertiser
e.g.: diy9-10Miller.pdf

*Abbreviations:

diy = diy Fachmagazin; DIN = DIY International; HF = HOLZFORUM;
pet = pet Fachmagazin; PWW = PET worldwide; AQ = Aquaristik;
Car = Caridina; GT = Gartenteich

Data by data carrier

Use can be made of any current data carrier.

Programs suitable for direct processing

InDesign CS2, CS3, CS4 (Mac + PC);
Illustrator CS2, CS3, CS4 (Mac + PC);
PhotoShop 7.0, CS2, CS3, CS4 (Mac + PC);

You'll find information on the technical specifications for loose inserts, bound inserts, tip-on cards and product samples on the internet at www.daehne.de/media

Dähne Verlag

Your Dähne advertisement team



Managing director
Marc Dähne
m.daehne@daehne.de
Phone +49/7243/575-102



Advertising manager
Thomas Heinen
t.heinen@daehne.de
Phone +49/7243/575-110



**Advertisement sales
per Fachmagazin
PET worldwide**
Patricia Bader
p.bader@daehne.de
Phone +49/7243/575-104



**Advertisement sales
Aquaristik, Caridina,
Gartenteich**
Angelika Müller
a.mueller@daehne.de
Phone +49/7243/575-105



**Advertisement sales
diy Fachmagazin
DIY International
HOLZFORUM**
Manuel Weber
m.weber@daehne.de
Phone +49/7243/575-106



**Advertisement
administration**
Gabriele Santai
g.santai@daehne.de
Phone +49/7243/575-103

The advertising agent for your country:



**Advertisement
administration**
Christa Mantel
c.mantel@daehne.de
Phone +49/7243/575-102



Benelux/Scandinavia
Lothar Wittich
Westfehling Development GmbH
Phone +49/54 39/80 90 00
Fax +49/54 39/8 00 99
l.wittich@daehne.com



France
Martine Kilias
Westfehling Development GmbH
Phone +49/54/1 50 51 97
Fax +49/54/1 70 31 76
m.kilias@daehne.com



Italy
Gloria Oddone-Ebken
Westfehling Development GmbH
Phone +49/54/1 6 00 52 08
Fax +49/54/1 6 00 52 09
g.oddone-ebken@daehne.com



USA/Canada/UK/Ireland
Marie-Anne Vonstein
Westfehling Development GmbH
Phone +49/5452/91 75 68
Fax +49/5452/91 75 68
m.vonstein@daehne.com



Taiwan
Joy Wang
Infotrade Media Co., Ltd.
No. 508, Sec. 3,
Wen Hsin Rd., Situn Dist.
Taichung 40753, Taiwan
Phone +886/4/23 13 21 89 203
Fax +886/4/23 13 32 39
service@trade-eye.com